



DNH

HEAD OFFICE, NORWAY
DNH AS

Phone..... + 47 35 98 56 00
Fax..... + 47 35 98 56 10
E-mail..... dnh@dnh.no
Web-Site..... www.dnh.no

ENGLAND
DNH WW Ltd

Phone..... + 44 1908 275 000
Fax..... + 44 1908 275 100
E-mail..... dnh@dnh.co.uk

GERMANY
DNH GmbH

Phone... + 49 040 6569 30-0
Fax..... + 49 040 6569 30-30
E-mail..... dnh@dnh.de

USA
DNH Speakers Inc

Phone..... + 1 484 494 5790
Fax..... + 1 484 494 5793
E-mail..... dnh@dnhspeakers.com

DSP-15EExmNL(T)

ISO 9001 CERTIFIED

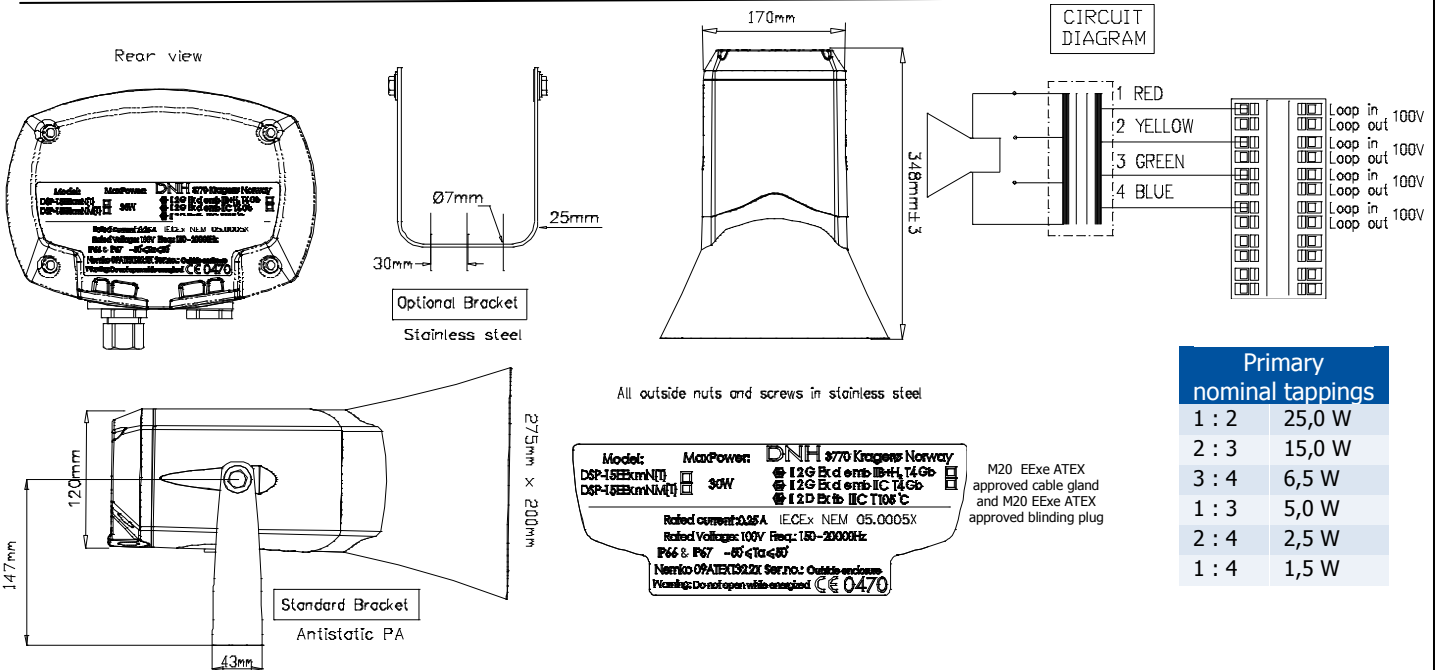

Primary nominal tapings	
1 : 2	25,0 W
2 : 3	15,0 W
3 : 4	6,5 W
1 : 3	5,0 W
2 : 4	2,5 W
1 : 4	1,5 W

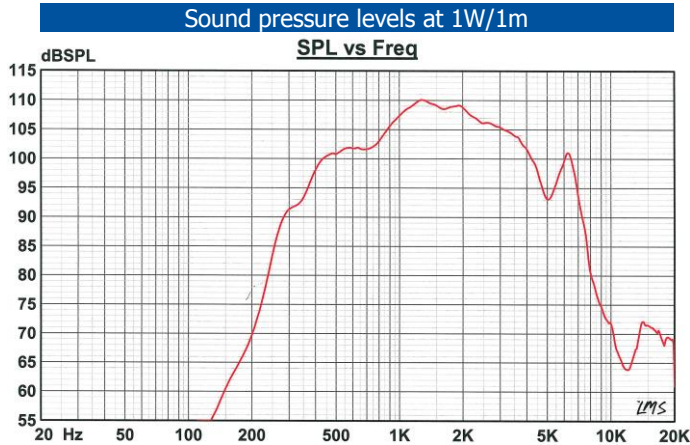

Specifications	IIB	IIC
Material / Color	Anti-static PA / Black	
Mounting	Bracket	
Termination	e-chamber, push terminals	
Weight w/transformer	2,8 kg	
IP-rating	66 / 67	
Max. / min. amb. temp	50°C / -50°C	
Rated / max. power	25 W / 30 W	
SPL 1W/1m	109 dB	106 dB
SPL rated power	121 dB	118 dB
Effective freq. range	330 – 7000 Hz	450-6000
Dispersion (-6dB) 1kHz / 4kHz	200° / 50°	105° / 35°
Directivity factor, Q	3,9	
Options	Impedances, colors, labels	

Installation, Operation and Maintenance Procedures

- Remove lid by 4 screws, lead cable through the cable gland and connect to terminal with required tapping.
- Screw lid back into place by 4 screws with a torque of 2 - 3 Nm to assure the IP rating.
- To change the position of the loudspeaker, please adjust the standard U- bracket (by loosening / tightening the screws) as required.
- Use only certified/specified cable glands and blanking plugs, reflecting the same IP rating and temperature range as the loudspeaker.
- DSP-15 EExmNL(T) can be supplied with 3 different bracket systems, according to customer requirements.
- For optimum performance, always use the correct voltage / power and operate within the frequency limits as stated.
- Do not open loudspeaker when energized.
- This loudspeaker is supplied with a 2 year warranty against defective workmanship.

DNH reserves the right to alter specifications without notice

